

MP PUMPS RBS SERIES

RBS INSTALLATION, OPERATION, AND REPAIR MANUAL

RBS is a long life, zero maintenance circulator pump for pumping glycol/water specifically for transit bus applications. The pump/motor does not have seals, bearings, or magnets to wear out or fail. The pump/motor design is a canned type with a cartridge as a single replacement item. The motor drive and motor are protected with a variety of solid-state automatic controls to achieve long life and eliminate maintenance.

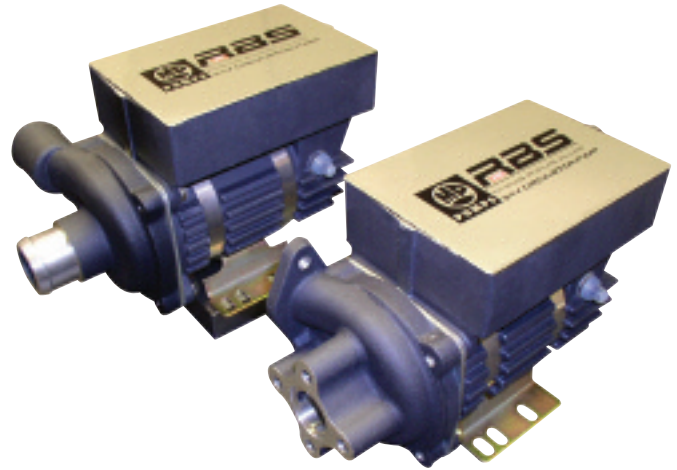

GENERAL SAFETY INFORMATION:

THE FOLLOWING WARNINGS ARE USED TO NOTIFY AND ADVISE THE USER OF THIS PRODUCT OF PROCEDURES THAT MAY BE DANGEROUS TO THE USER OR RESULT IN DAMAGE TO THE PRODUCT.

THIS BULLETIN MUST BE READ COMPLETELY BEFORE INSTALLING, OPERATING, OR SERVICING, THE PUMP.

- **DO NOT** perform service or maintenance when the pumping system is pressurized. Injury or death may occur.
- **DO NOT** operate the pump in a manner that it was not intended to be used.
- **DO NOT** mount the pump such that high piping loads exist on the pump flanges, or in a rigid piping system that does not allow the pipe to expand and cause the pump to be strained.
- **DO NOT** continue to operate the pumping system when a known leak exists.
- **DO NOT** continue to operate the pump when unusual noise or vibration occurs.
- **DO NOT** operate beyond the pressure or temperature limits stated in the product literature. See Form 8111.
- **DO NOT** allow severe temperature changes to occur in a short time period within the pumping system.

INSTALLATION:

Install the pump in the best environmental location to minimize vibration, temperature, exposure to moisture, and impact from debris.



MP PUMPS, INC.

34800 BENNETT • FRASER, MI 48026-1686
(586) 293-8240 • FAX (586) 293-8469
(800) 563-8006 • www.mppumps.com

FORM 3806-(11-06)

PIPE CONNECTION AND MOUNTING:

The *RBS* has optional housings for 1.5-inch hose or two bolt flat flanges. Flat flanges have an o-ring/quad ring groove instead of a gasket. A quad ring provides the most positive seal (DO NOT use sealant on the flanges). When rigid mounting the flange connections, the motor base may need to be shimmed to fit the installation to avoid stress on the base. Isolation valves can be installed where the pump does not support the weight of the valve.

Hose connections are made for 1.5 inch ID hose. The hoses should be free of kinks and sharp bends particularly at the inlets where the hose may collapse.

The pump can be mounted horizontally or vertically in any position.

ELECTRICAL:

The motor must be protected from over current by using a 10-15 amp fuse. Minimum wire size for the 24 volt motor is 16 gage. The acceptable operating voltage range is 22 to 30 volts DC.

OPERATION:

The *RBS* can operate dry for a short period of time. Reduced pump life will occur when the pump in run dry for more than 5 minute intervals.

If the impeller becomes obstructed or locked up, the circuit breaker will release. The breaker can be reset to restart the motor. Repeated circuit breaker tripping may indicate that the wet rotor shaft bearings are worn beyond usable limits. Repeated circuit breaker tripping may also indicate a damaged impeller or the presence of an obstruction. The wet rotor assembly is a service item that can be replaced.

The *RBS* is equipped with an internal over temperature control circuit that will shut down the motor when the internal temperature exceeds a high limit. The pump/motor will restart automatically when the temperature returns to a safe level.

REPAIR:

The only wear replacement item that may need to be serviced is the wet rotor assembly. It is recommended to bench test the pump/motor after service. If the motor will not operate properly after renewing the cartridge, the winding or control has terminally failed and will require replacement of the entire unit.

CARTRIDGE REPLACEMENT INSTRUCTIONS:

1. Remove the four capscrews holding the pump volute housing onto the motor shell. Remove the volute by prying it away from the back plate. Remove the o-ring and discard.
2. Remove the cartridge assembly by pulling it out of the motor shell with the back plate.
3. Inspect the motor stator winding visually by looking into the opening where the cartridge was positioned. Dark discolored laminations and stator wire may indicate that the stator has failed from high heat.
4. Replace with a new cartridge assembly and back plate by pushing the cartridge through the rubber gasket, through the back plate and through the other rubber gasket. Pilot this assembly into the motor winding and push until flush with the motor face. When properly installed, the holes in the gasket, back plate and motor shell will all line up. Make sure there are no wrinkles in the gasket material.
5. Place a new o-ring into the pilot of the volute housing.
6. Install the volute housing over the cartridge with the holes indexed to line up the pump outlet in the proper position. Install the four capscrews with the lockwashers. Check the impeller for clearance by rotating the impeller through the inlet. It should rotate freely.
7. Bench test the pump by applying 24VDC power to the motor. The impeller should spin at approximately 3000rpm. If it fails to rotate, check the circuit breaker and reset if necessary.

ITEM	QTY	PART NO.	DESCRIPTION
1			HOUSING OPTIONS:
	1	33552	HOUSING - FLANGED
	1	33850	HOUSING - 1.50 HOSE
2	1	33561	O-RING - VITON
3	1	33568	IMPELLER/CARTRIDGE ASSEMBLY
4	2	35152	GASKET - VITON
5	1	33560	BACK PLATE
6	1	33669	MOTOR SHELL ASSEMBLY
7	4	33564	LOCK WASHER - SS
8	4	33563	HEX HEAD CAPSCREW - SS
9	1	28866	BASE
10	2	33564	LOCKWASHER - SS
11	2	30551	HEX HEAD CAPSCREW - SS

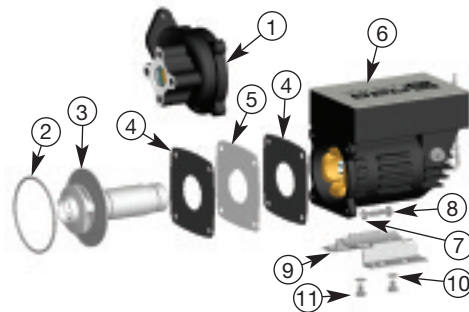

TROUBLE SHOOTING GUIDE		
CONDITION	PROBLEM	CAUSE
Pump/motor will not run	Motor	Power voltage to low/high Power polarity in reverse Circuit breaker tripped Locked rotor condition Damaged motor drive/winding
	Pump	Obstruction in the pump Impeller rubbing/damaged Cartridge worn beyond limits
Motor runs intermittently	Motor	Voltage near lower/upper limits Environmental temperature too high
Circuit breaker trips	Motor	Excessive current draw from high load Locked rotor condition
	Pump	Obstructed impeller Cartridge worn beyond limits