

SMF SERIES

STAINLESS MAX FLOW FEATURES

DESIGN FEATURES

- AVAILABLE HORSEPOWER: 1HP, 1.5HP, AND 2HP
- AVAILABLE CONNECTION: FLANGE MOUNTED
- AVAILABLE FLOW RATE: 350 GPM AT 7PSI
- AVAILABLE MOTOR VOLTAGE: 115/208/230V, 208/230/460V, 190/380V, 415V, 575V

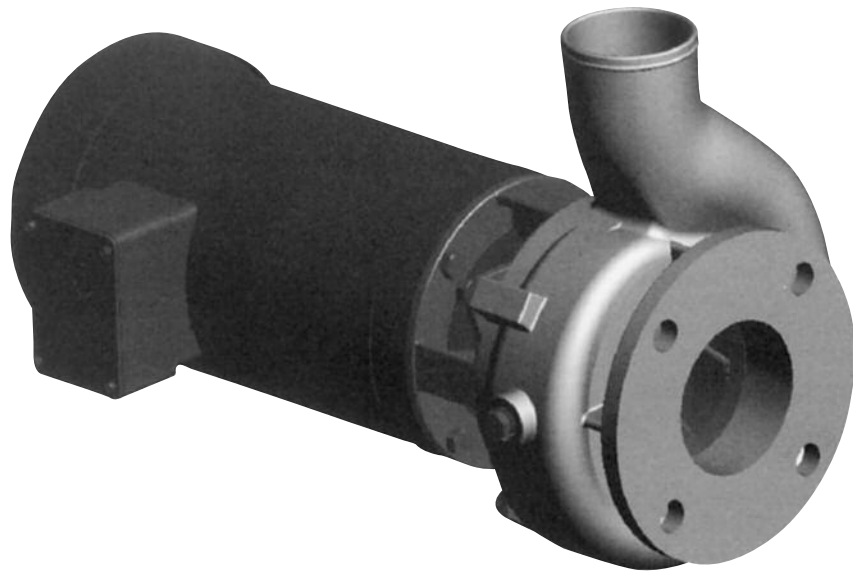

SMF

SMF PERFORMANCE CURVE

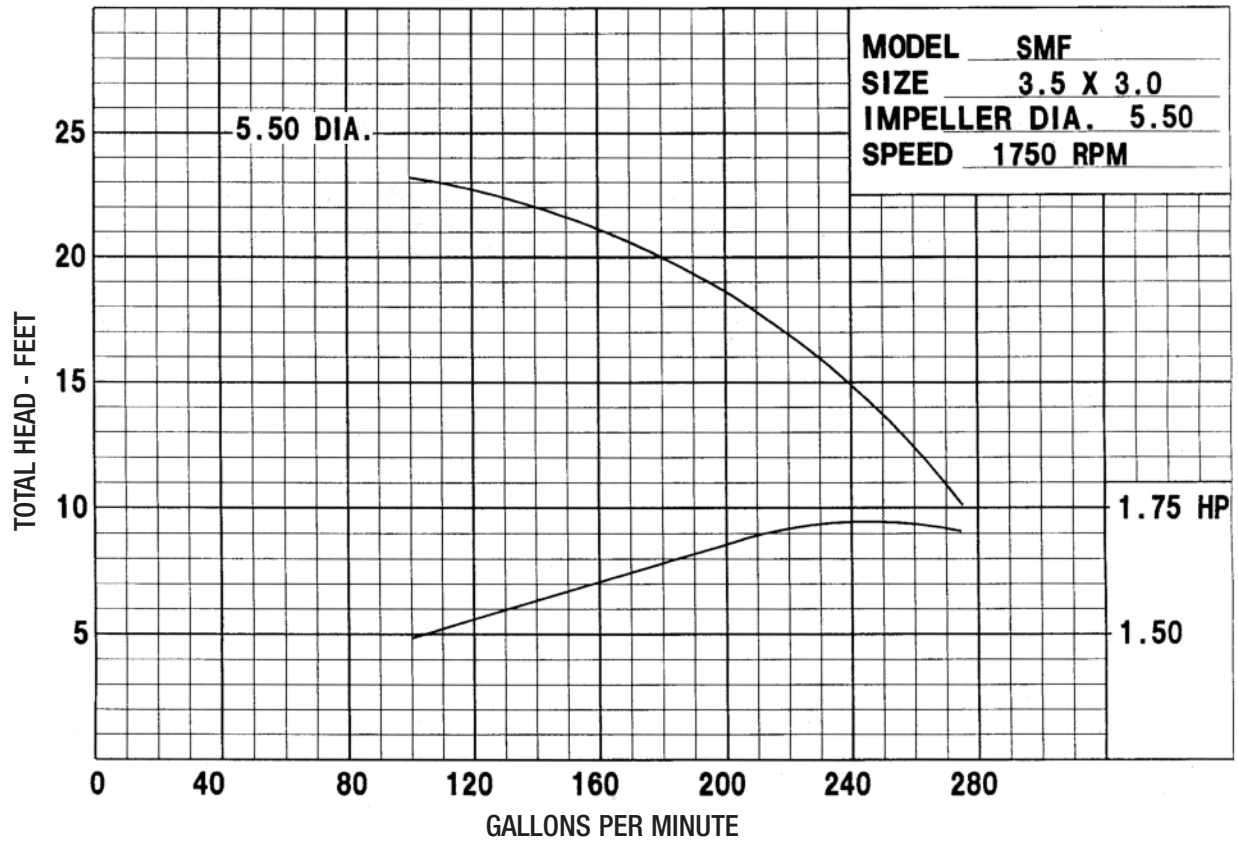

SMF DIMENSIONS

