

ECONOMICAL SELF-PRIMING PUMP FEATURES

- ALL CAST IRON CONSTRUCTION
- CHEMICAL DUTY CARBON/CERAMIC/VITON SEAL
- 303SS DRIVE SLEEVE
- CLOSE-COUPLED C-FACE MOTOR, ENGINES OR BEARING PEDESTAL
- BACK PULL-OUT DESIGN FOR EASY MAINTENANCE
- PUMP AND MOTOR COMPLETE IN A COMPACT, LIGHT WEIGHT PACKAGE
- IN STOCK FOR IMMEDIATE SHIPMENT

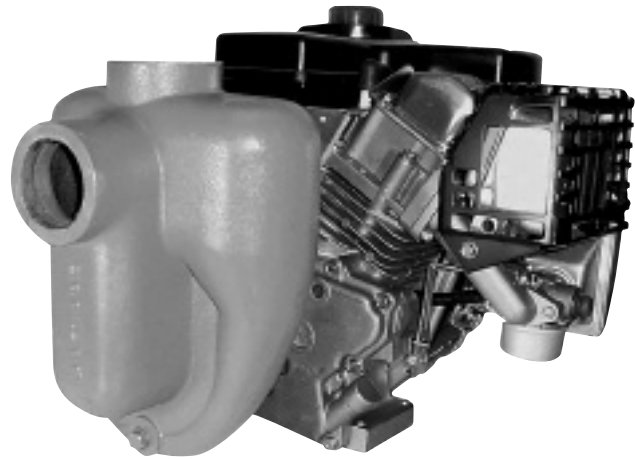

EMAX 8

MODEL	Suction	Discharge	Max. Solid Size
EMAX 8	2" NPT	2" NPT	.56"

EMAX Dimensions

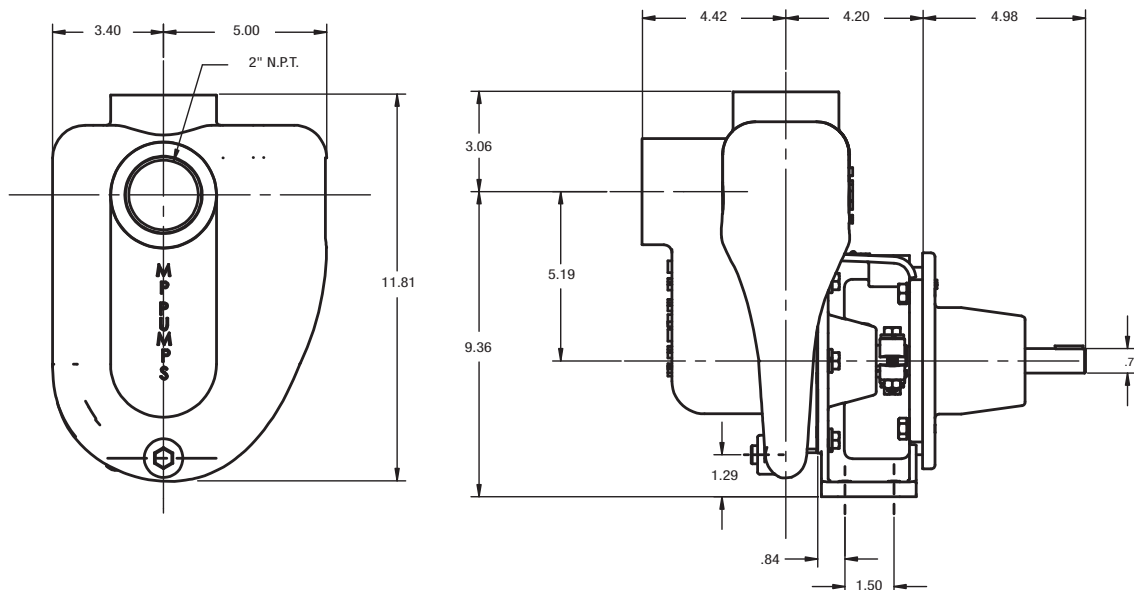

EMAX Pump Performance Curves

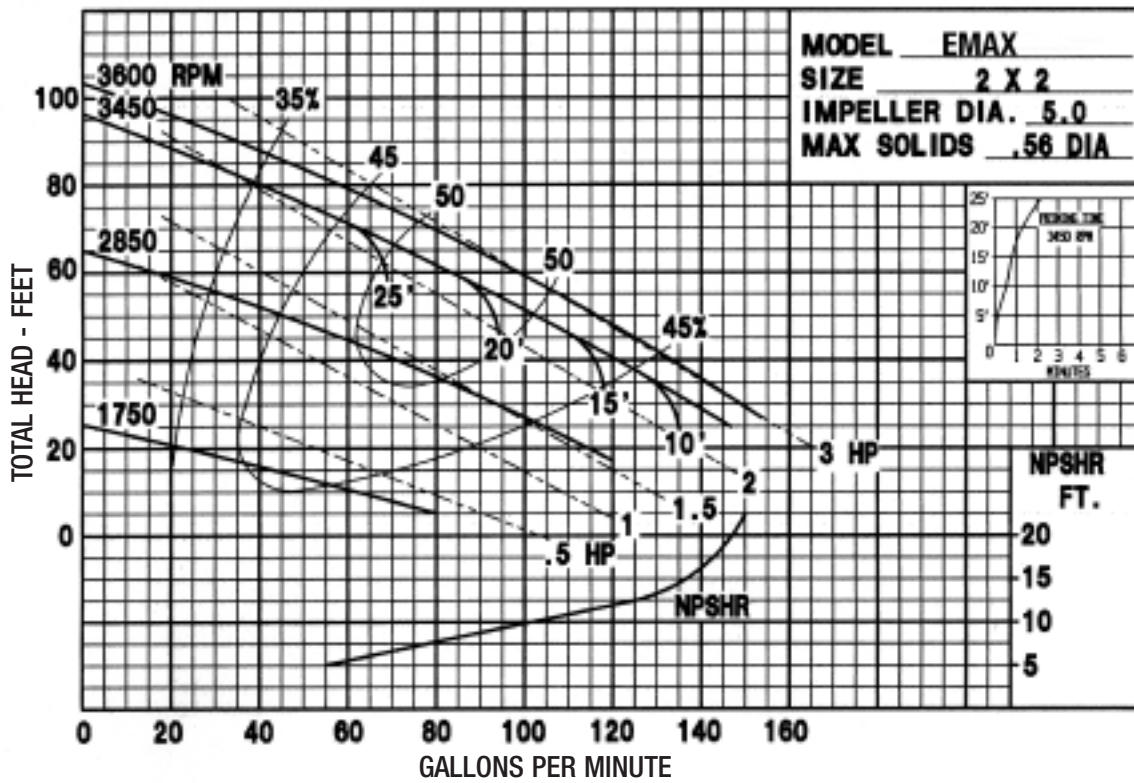

EMAX Dimensions

