

MP PUMPS, INC.

FRX 50 FRX 50-R Centrifugal Pumps

The FRX 50 is a high performance 316 stainless steel circulator pump making it ideal for marine, commercial, and industrial transfer of chemicals or potable water.

All pumping parts are 316 stainless steel for superior corrosion resistance when pumping chemical compounds. A carbon, ceramic, viton bellows shaft seal is standard. The FRX 50 series is available with 1/2" NPT and 1" hose barb port configurations. Model FRX 50-R is designed with 1" hose barb ports. Marine ignition protected motors available.

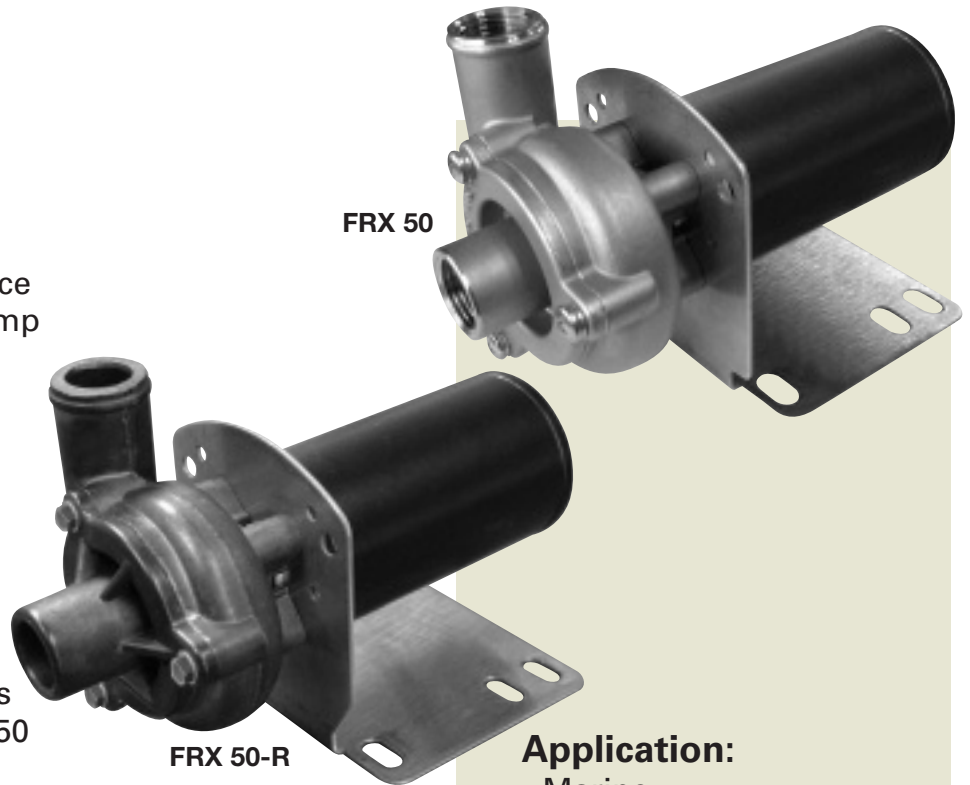

FRX 50

FRX 50-R

Application:

- Marine
- Industrial
- Commercial
- OEM

Construction:

- 316 Stainless Steel Investment Cast
- Polyphenylene Sulfide (PPS)

Motor Options:

- AC
- DC

Port Sizes:

- 1/2" NPT
- 1" Hose

Seal:

- Carbon / Ceramic / Viton

SPECIFICATIONS:

Housing	316 Stainless Steel (Investment Cast) (Optional Material PPS)
Cover	316 Stainless Steel (Investment Cast) (Optional Material PPS)
Impeller	316 Stainless Steel, Semi-Open (Sintered PM)
Mechanical Seal . .	Carbon/Ceramic/Viton Bellows 150 PSI Special Seals Upon Request
Base	304 Stainless Steel
O-ring	Viton
Motor	12V DC and 24V DC 115V AC and 230V AC
Weights	FRX 50 W/AC Motor 9 lbs. FRX 50 W/DC Motor 4 lbs. FRX 50-R W/AC Motor 5 lbs. FRX 50-R W/DC Motor 10 lbs.

FRX 50 & FRX 50-R

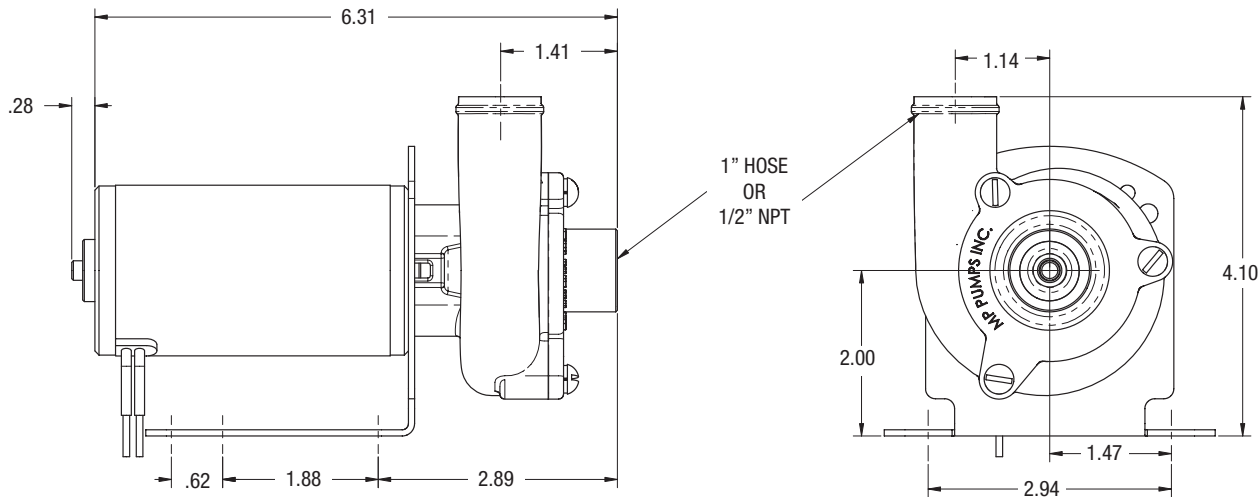

115V AC MOTOR

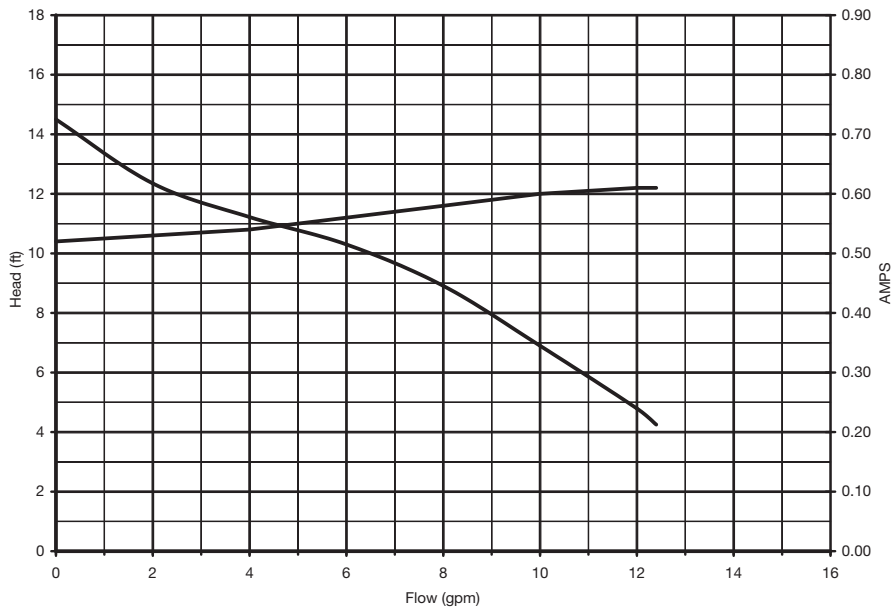

12V DC MOTOR FOR 24 V DC MOTOR DIVIDE AMPS BY TWO

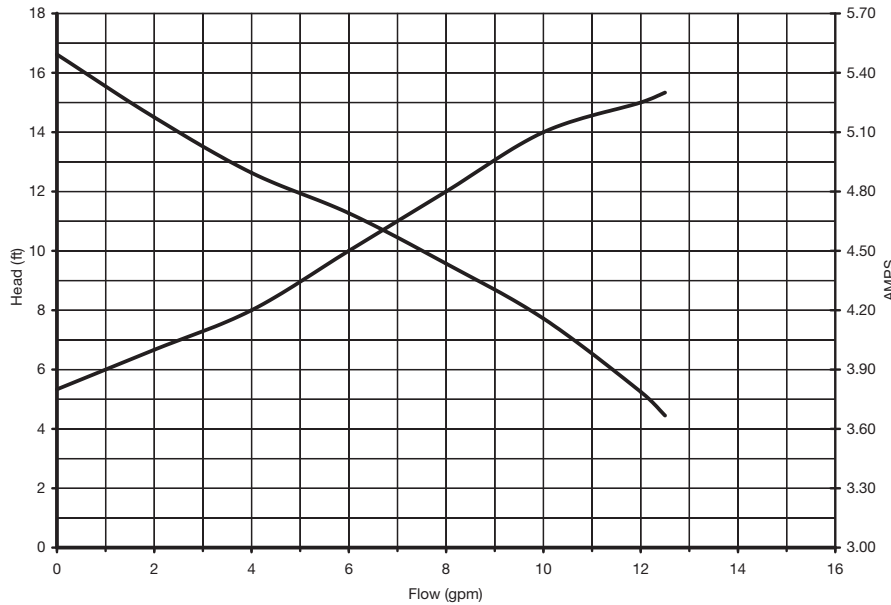

34800 BENNETT • FRASER, MI 48026-1686
 (586) 293-8240 • FAX (586) 293-8469
 (800) 563-8006 • www.mppumps.com

www.mppumps.com

FORM 8129-A (02/07)
 Litho in USA