

MP PUMPS, INC.

JF 168

Agricultural and Industrial Applications

MP Pumps offers an economical 5.5 HP engine for use with Flomax and Series pumps. The JF 168 is an overhead valve four cycle engine that meets off road EPA phase 2 standards and CARB standards.

Features low oil shutdown, dual element air cleaner, fuel shutoff valve, muffler guard, a 3-quart steel fuel tank, and manual choke/throttle controls.



P/N 35267

SPECIFICATIONS:

Length x Width x Height	12.3" x 14.3" x 13.2"
Dry Weight	33.1 lbs
Engine Type	4-Stroke, Overhead Valve, 1 Cylinder Ignition System
Displacement	9.9 Cubic Inches
(Bore x Stroke)	(2.7" x 1.8")
Idle Speed	1,400 RPM
Maximum Output	5.5 HP @ 3,600 RPM
Cooling System	Forced Air
Ignition System	Transistorized Magneto
PTO Shaft Rot.	Counterclockwise

APPLICATIONS

- Agricultural
- Industrial

ADAPTABLE TO MODELS:

- Flomax 5
- Flomax 8
- Series 80

SERVICE PARTS AVAILABLE

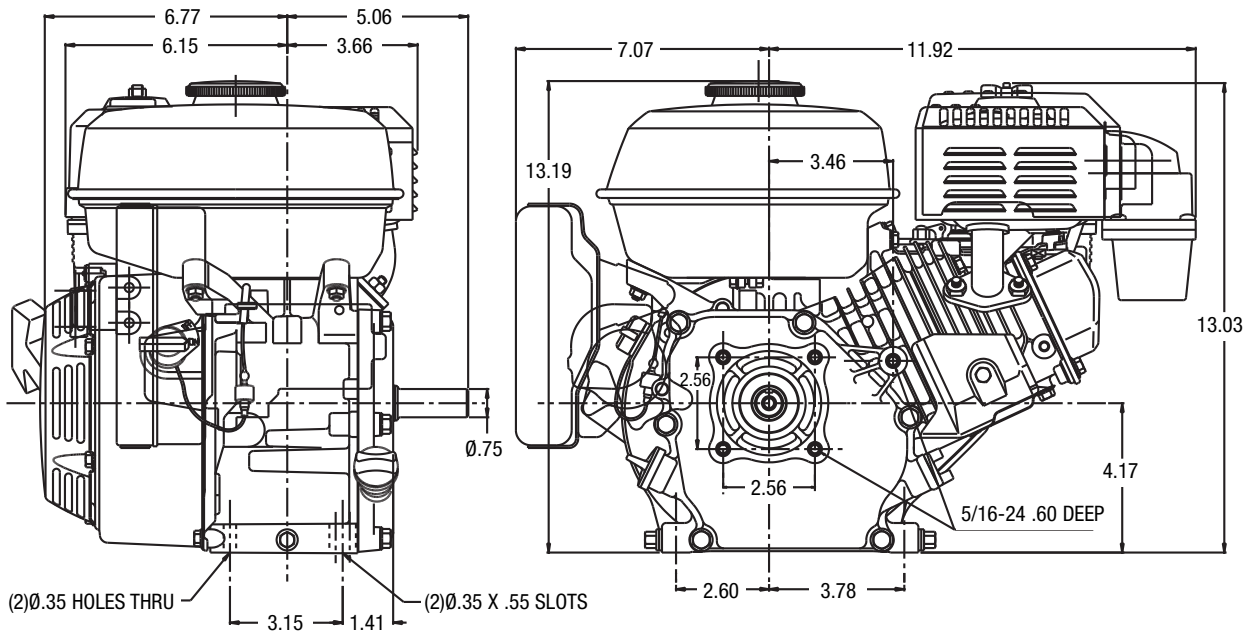
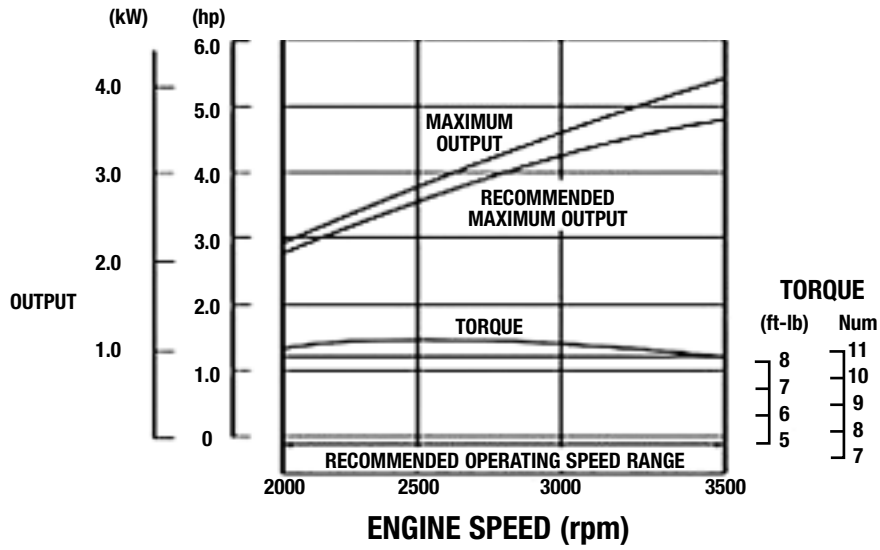

MP PUMPS, INC.

34800 BENNETT • FRASER, MI 48026-1686
 (586) 293-8240 • FAX (586) 293-8469
 (800) 563-8006 • www.mppumps.com