



FMX 75 HYDRAULIC

3/4" x 3/4" Self Priming Centrifugal Pump

Model FMX75 Hydraulic is a high performance self-priming 316 stainless steel centrifugal pump close coupled to a hydraulic motor. The pump is ideal for marine, agricultural, and industrial applications where suction lift is required.

The FMX75 HYD model features all 316 stainless steel components for superior corrosion resistance when pumping chemical compounds. A carbon / ceramic / Viton bellows shaft seal is standard. Ports are 3/4" NPT with a 1/8" NPT fill port. The check valve flapper design enhances the self priming capability to 12 foot suction lift.

The hydraulic motor is designed with SAE #6 ports for the tank side while the pressure side has SAE # 4 ports. Maximum Pressure is 1000 PSI. Maximum oil flow is 3 GPM.

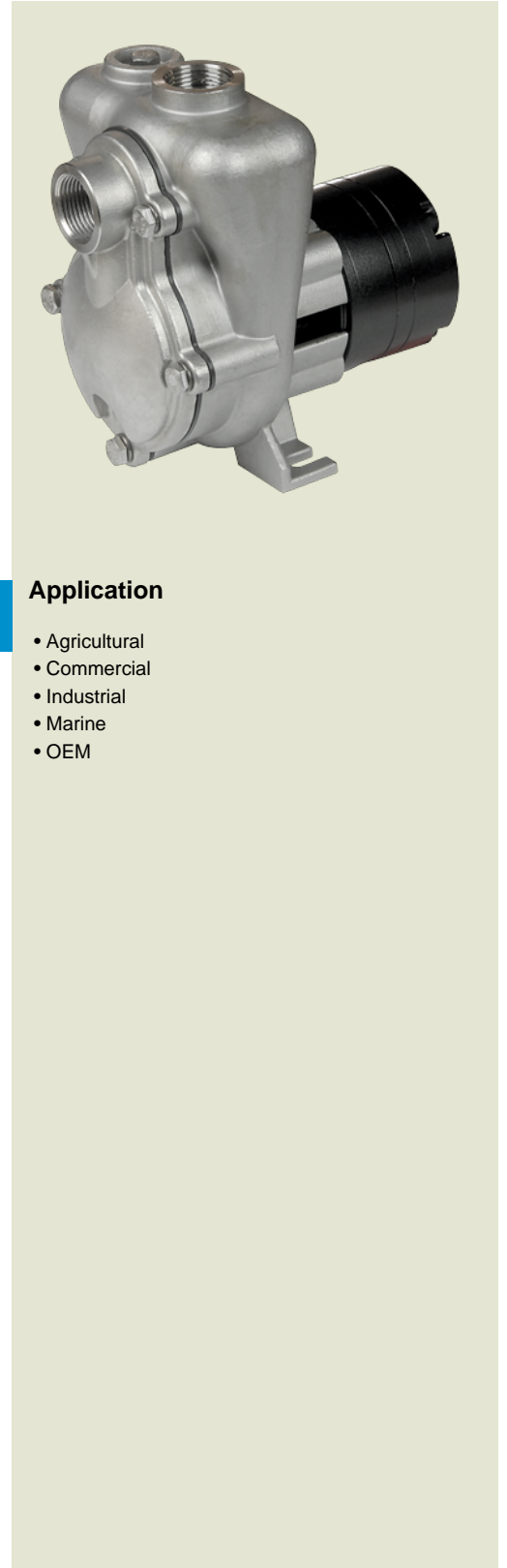

SPECIFICATIONS:

Suction And Discharge	3/4" NPT x 3/4" NPT
Materials Of Construction	316 stainless steel
Flow	Up to 30 GPM
Head Feet	Up to 50'
Impeller	316 stainless steel semi-open
Drive Options	Hydraulic motor .08 cu. in.
Seal	Special seals upon request, Standard carbon / ceramic / Viton
Psi	Up to 21 PSI
Hydraulic Fluid Flow	Up to 2.5 GPM
Patent	US PATENT # 8,202,046 B2
Hydraulic System Pressure	Up to 800 PSI

Application

- Agricultural
- Commercial
- Industrial
- Marine
- OEM

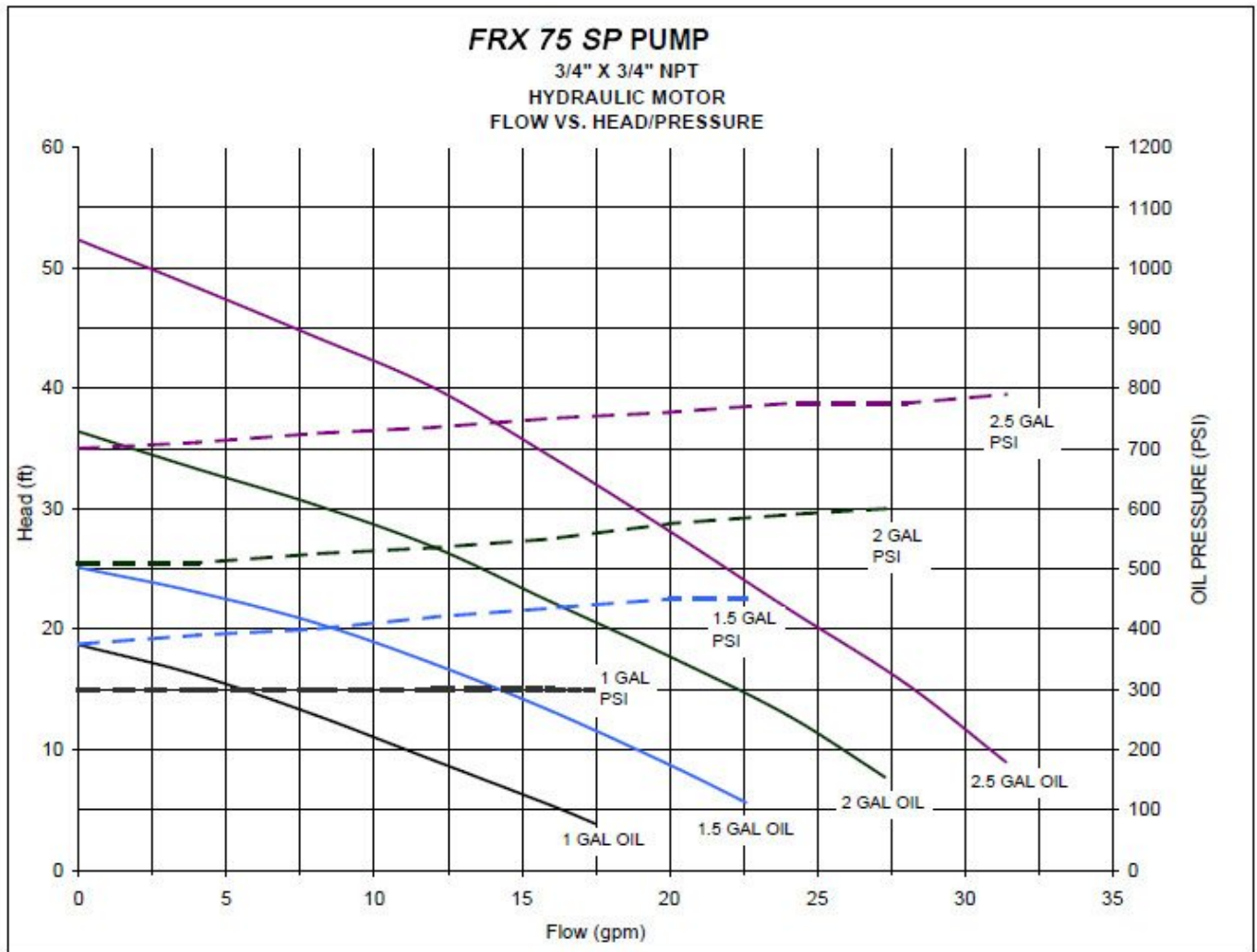

FMX 75 HYDRAULIC

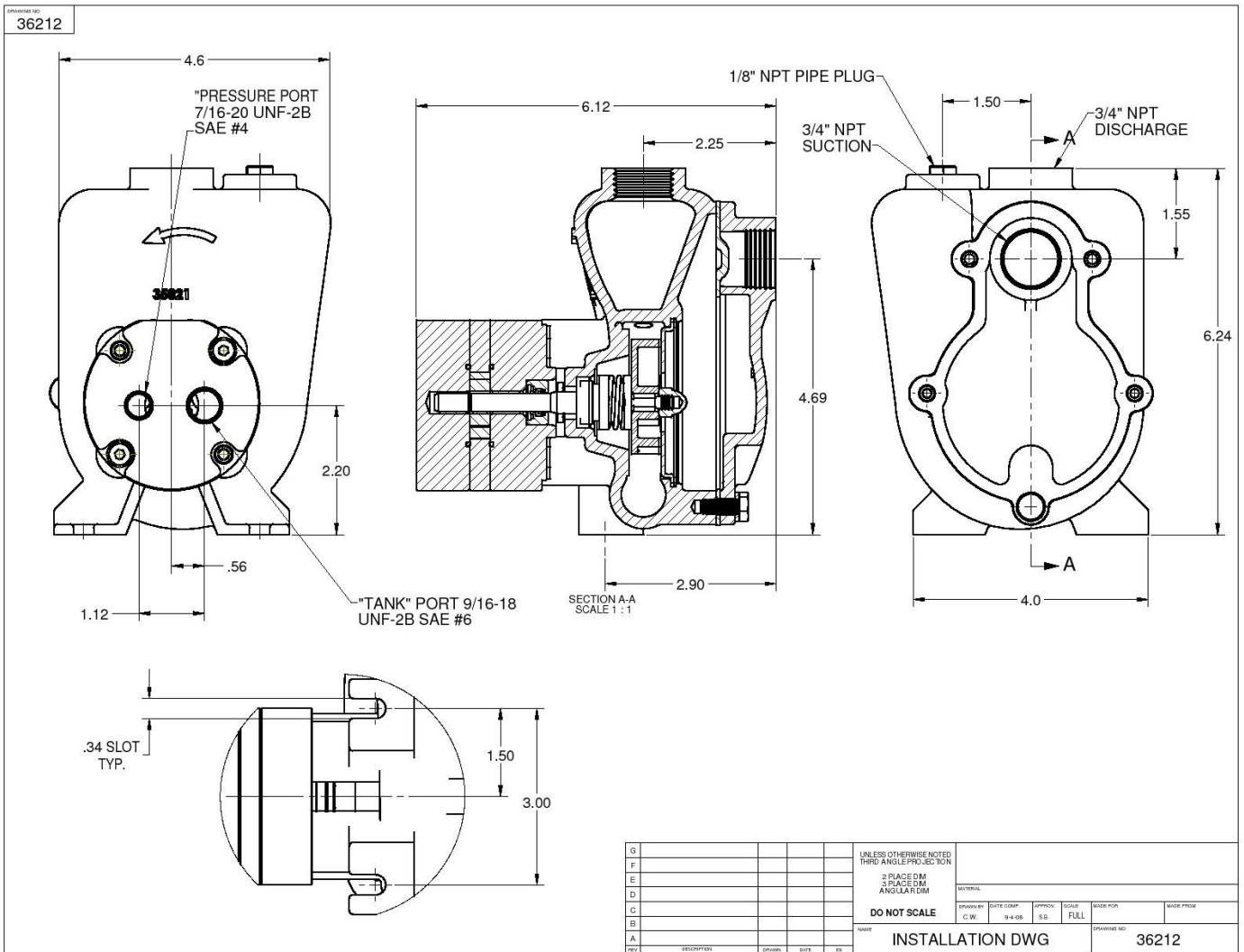

36212

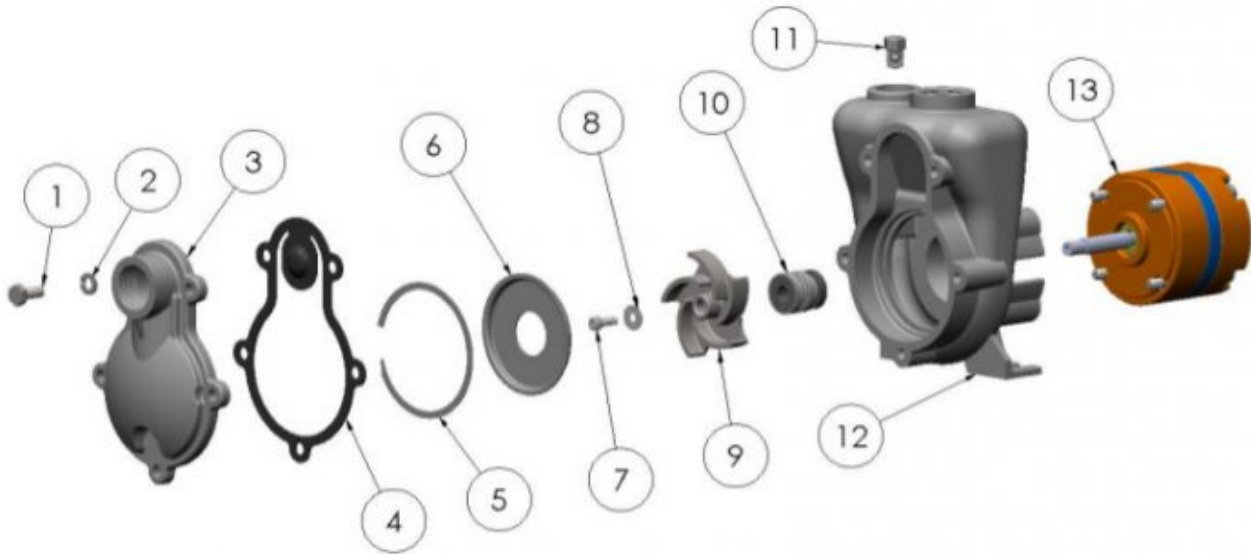

ITEM NO.	PART NO.	DESCRIPTION	QTY.
1	35039	H.H. CAPSCREW SS - 1/4-20 X 5/8	5
2	33564	LOCKWASHER SS - 1/4	5
3	35024	COVER-SS	1
* 4	35025	GASKET-VITON	1
5	35027	RETAINING RING - S.S.	1
* 6	35026	WEAR PLATE-SS	1
7	38106	CAPSCREW SS - 10-24 X .50	1
8	38107	LOCKWASHER SS - 3/16	1
9	34033	IMPELLER SS - PM	1
* 10	36863	SEAL ASY. TYPE 21 - 3/8"	1
11	21255	FILL PLUG SS - 1/8	1
12	35022	HOUSING-SS	1
13	36209	HYDRAULIC MOTOR ASY	1
14	36197	CAPSCREW STL 1/4-20X 2.25 N/SHOWN	2

* - RECOMMENDED REPLACEMENT PARTS